



US005367726A

United States Patent [19]
Chaffee

[11] **Patent Number:** **5,367,726**
[45] **Date of Patent:** **Nov. 29, 1994**

- [54] **PNEUMATIC SUPPORT SYSTEM**
- [76] **Inventor:** **Robert B. Chaffee**, 78 Montgomery St., Boston, Mass. 02116
- [21] **Appl. No.:** **992,814**
- [22] **Filed:** **Dec. 16, 1992**

3,536,071	10/1970	Ferrando	128/142.5
3,563,676	2/1971	Coovert et al.	417/410
3,600,727	8/1971	Williams	5/450
3,772,717	11/1973	Yuen et al.	5/349
3,785,395	1/1974	Andreasson	5/449 X
3,790,975	2/1974	Philipp et al.	5/349
3,798,686	3/1974	Gaiser	5/343
3,840,922	10/1974	Morrison et al.	5/350

(List continued on next page.)

Related U.S. Application Data

- [63] Continuation-in-part of Ser. No. 764,337, Sep. 23, 1991, which is a continuation-in-part of Ser. No. 557,943, Jul. 25, 1990, abandoned, which is a continuation-in-part of Ser. No. 384,786, Jul. 25, 1989, Pat. No. 4,977,633.
- [51] **Int. Cl.⁵** **A47C 27/08**
- [52] **U.S. Cl.** **5/449; 5/450;**
137/223; 137/226
- [58] **Field of Search** **5/449, 450, 455;**
137/226, 223, 544, 549, 599.2; 251/339

FOREIGN PATENT DOCUMENTS

2050844	1/1981	United Kingdom .
WO93/05684	4/1993	WIPO .

Primary Examiner—Michael F. Trettel
Attorney, Agent, or Firm—Bromberg & Sunstein

[57] **ABSTRACT**

A portable, inflatable support system, and a portable inflator for use with such a system are provided in one embodiment. The inflatable support system may include an inflatable mattress having a pressure valve and a battery powered inflator for removable engagement therewith, which on engagement is automatically powered for a predetermined time or until a predetermined pressure is achieved. The mattress may be readily expanded for use and collapsed for storage. Another embodiment provides a multipurpose pressure control, for manual adjustment to provide an inflatable support system of desired firmness, and to modify the posture of the reclining user. A dual valve assembly includes a cover assembly that removably covers a throat, and the cover assembly is itself provided with a one-way valve. Another embodiment provides an in-place bedding system, including a mattress, mattress cover, and top and bottom bedsheets, which retain their functional arrangement when the bed is collapsed for storage and prepared for use, thereby eliminating the necessity for re-making the bed with each use.

[56] **References Cited**

U.S. PATENT DOCUMENTS

388,037	8/1888	Hargin .	
679,519	7/1901	Smith .	
918,391	4/1909	Taarud .	
1,185,684	6/1916	Kraft et al. .	
1,263,599	4/1918	Poole .	
1,451,136	4/1923	Allnutt .	
1,944,466	1/1934	Rubin	5/343
2,059,226	6/1935	Gates	5/347
2,112,641	9/1936	Wheaton	277/61
2,369,736	2/1945	Hurt	5/343
2,372,218	3/1945	Manson et al.	5/348
2,415,150	2/1947	Stein .	
2,549,597	4/1951	Harris et al.	5/348
2,573,375	10/1951	Winstead	230/32
2,701,579	2/1955	Hasselquist	137/223
2,741,780	4/1956	Kimbrig	5/348
2,842,783	7/1958	Druck	5/348
3,042,941	7/1962	Marcus	5/348
3,066,323	12/1962	Kintner	5/334
3,068,494	12/1962	Pinkwater	5/348
3,128,480	11/1962	Lineback	5/348
3,155,991	11/1964	Dunham	5/348
3,505,695	4/1970	Bishaf et al.	5/348

20 Claims, 13 Drawing Sheets

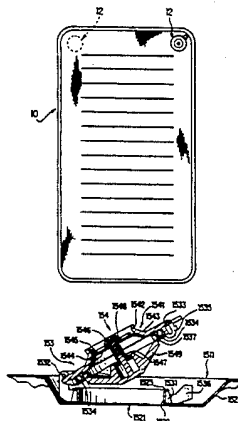

U.S. PATENT DOCUMENTS

3,864,766	2/1975	Prete, Jr.	5/450 X	4,579,141	4/1986	Arff	137/522 X
3,877,092	4/1975	Gaiser	5/343	4,644,597	2/1987	Walker	5/449
3,983,907	10/1976	Sorensen	137/223	4,678,014	7/1987	Owen et al.	141/67
3,995,653	12/1976	Mackal et al.	137/223 X	4,734,017	3/1988	Levin	417/366
4,025,974	3/1977	Lea et al.	5/367	4,766,628	8/1988	Walker	5/449
4,080,105	3/1978	Connell	417/26	4,829,616	5/1989	Walker	5/453
4,149,285	4/1979	Stanton	5/347	4,862,533	9/1989	Adams, III	5/454 X
4,169,295	10/1979	Darling	5/450	4,896,389	1/1990	Chamberland	5/453
4,176,681	12/1979	Mackal	137/516.29	4,897,890	2/1990	Walker	5/453
4,371,999	2/1983	Reid	5/457	4,970,741	11/1990	Spina	5/417
4,442,838	4/1984	Samson et al.	128/369	4,977,633	12/1990	Chaffee	5/453
4,488,323	12/1984	Colburn	5/460	4,982,466	1/1991	Higgins et al.	5/453
4,521,166	6/1985	Phillips	417/478	5,068,933	12/1991	Sexton	5/441
				5,111,838	5/1992	Langston	137/223

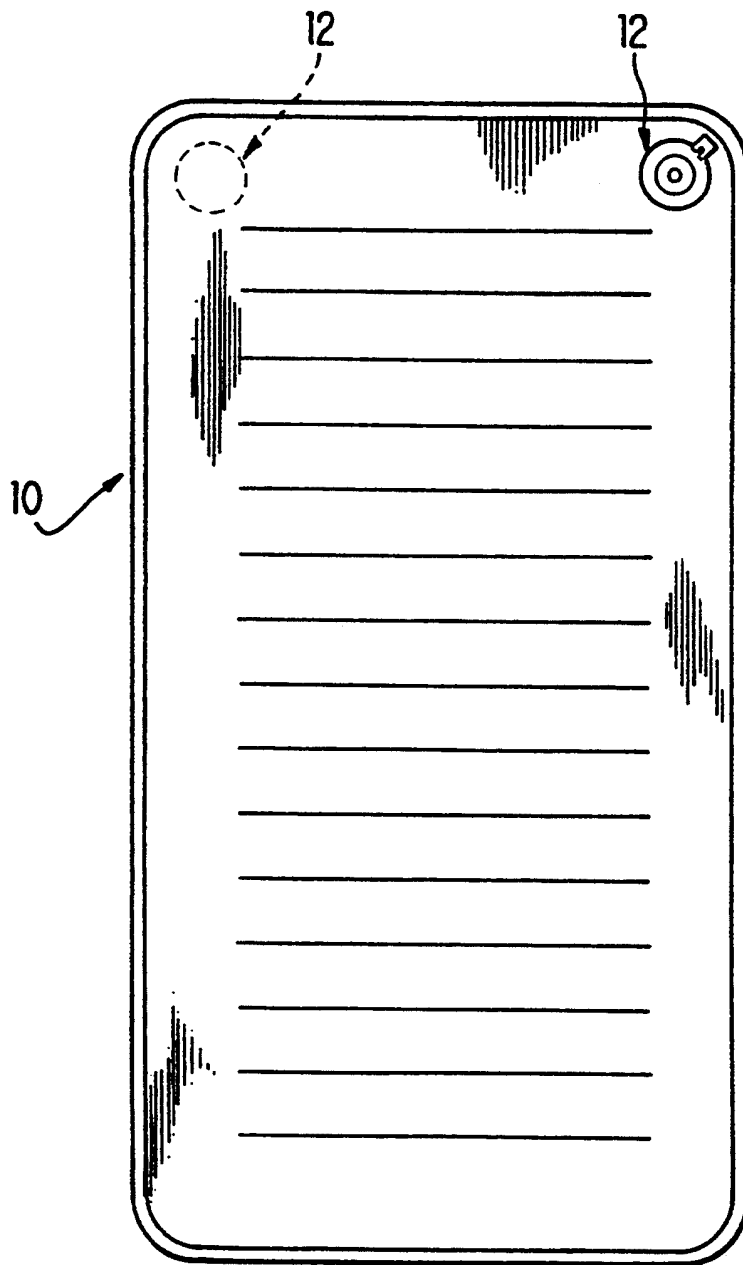

FIG. 1

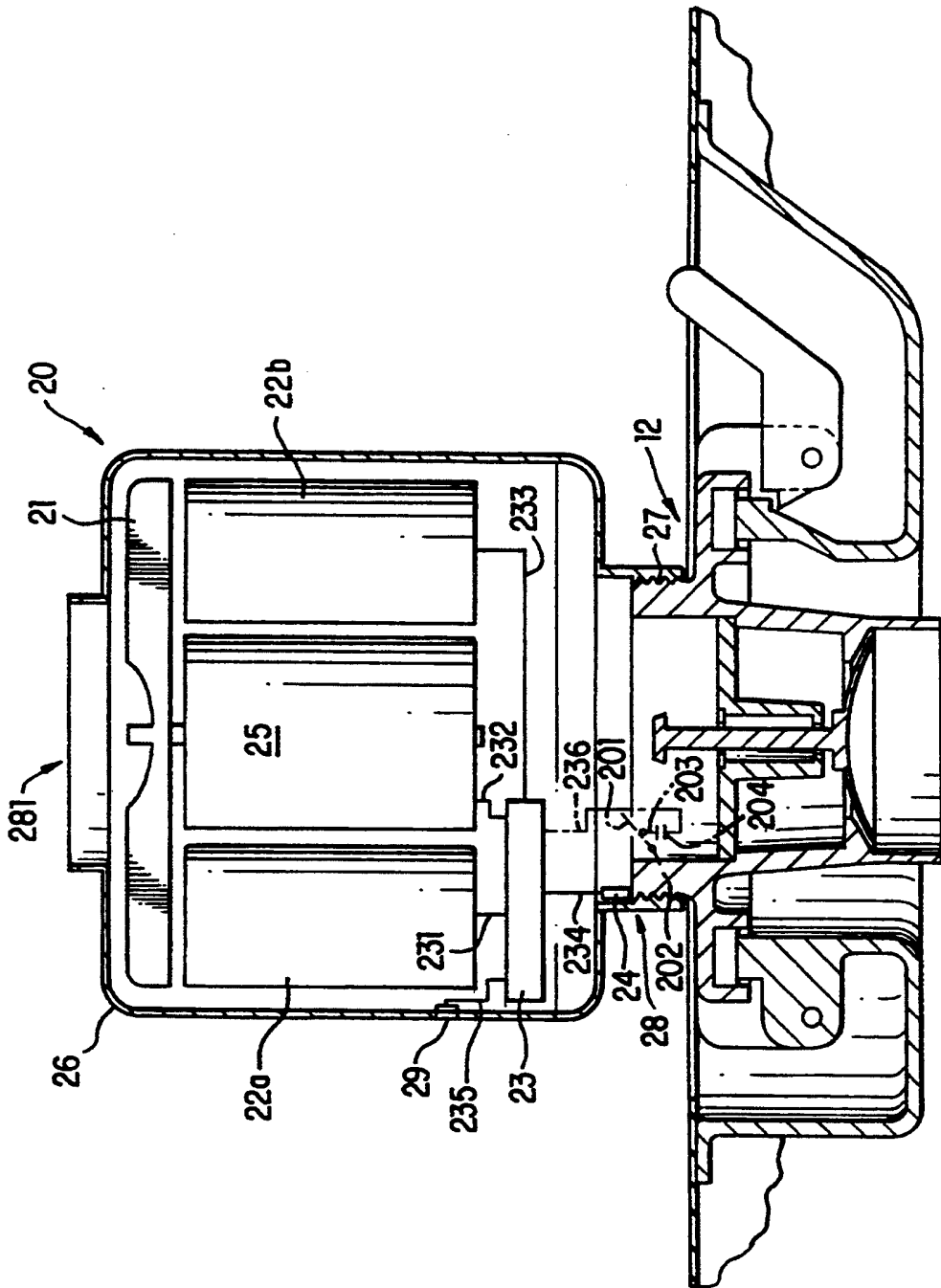

FIG. 2

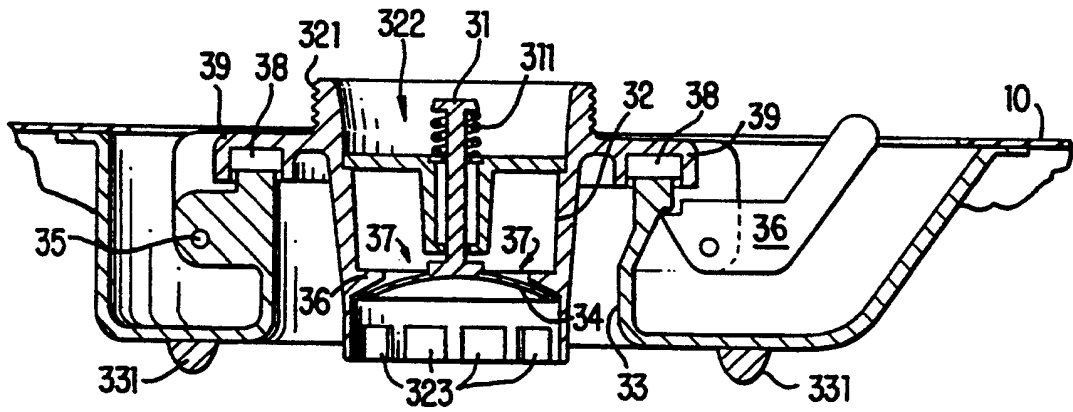

FIG. 3

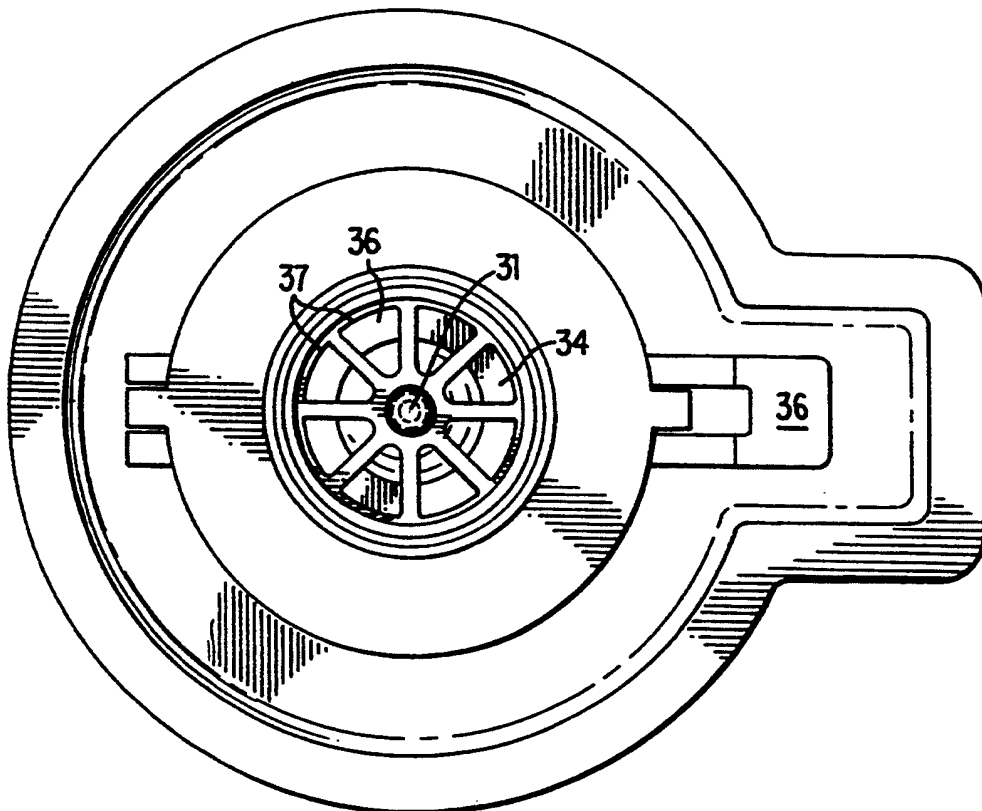

FIG. 4

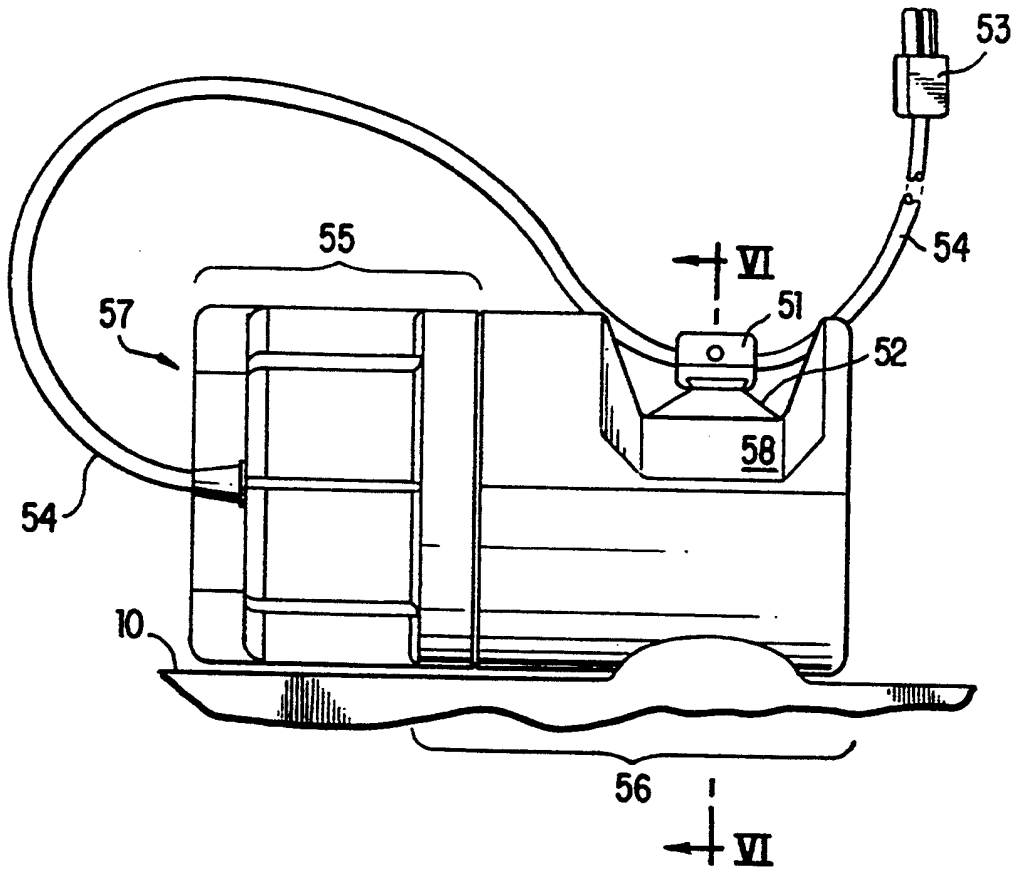

FIG. 5

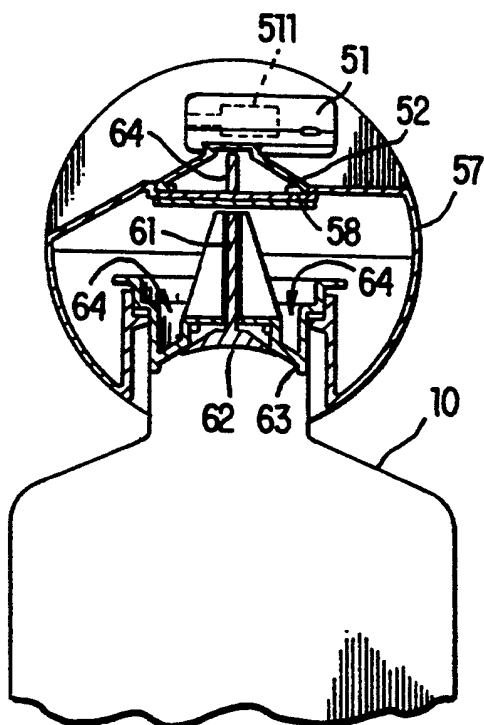

FIG. 6

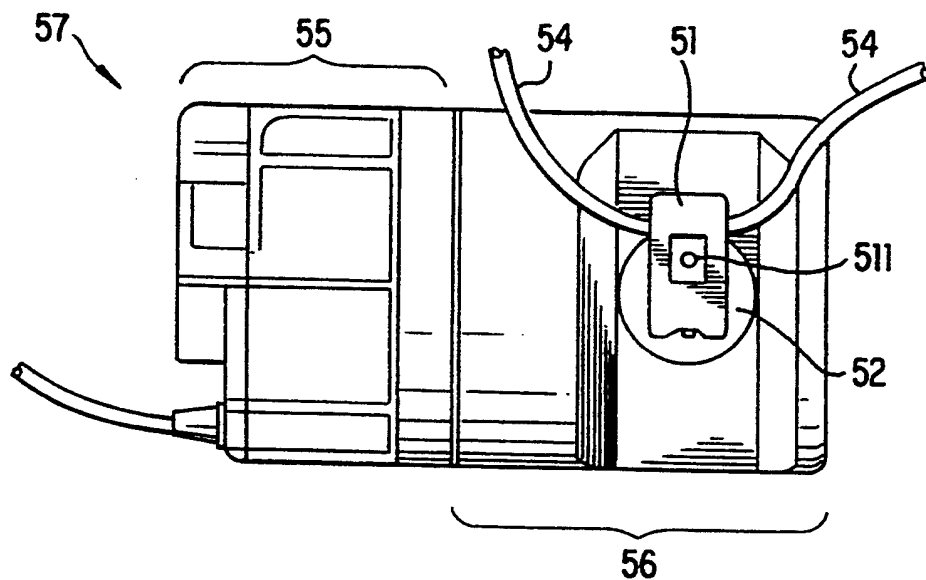

FIG. 7

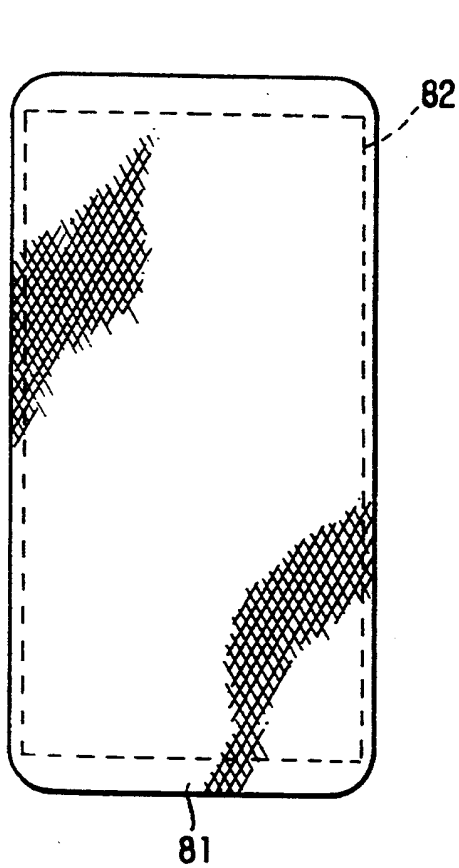

FIG. 8

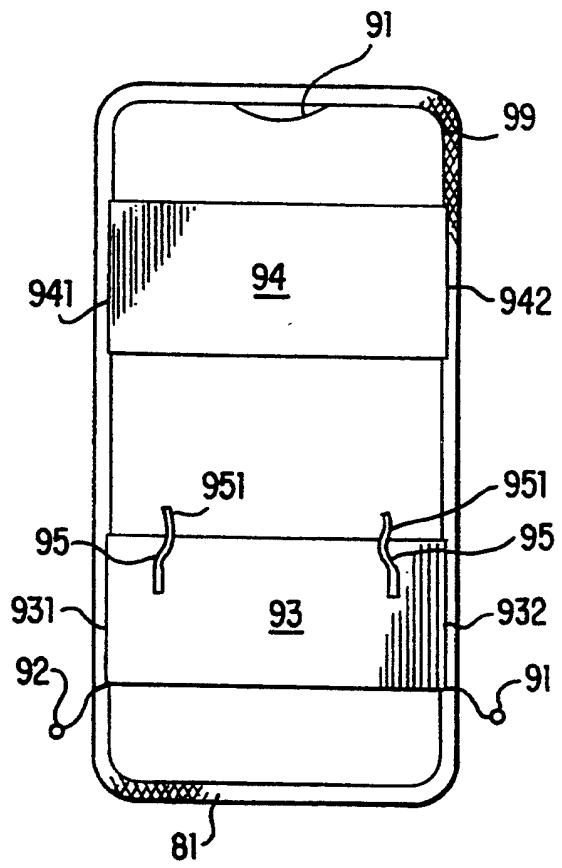

FIG. 9

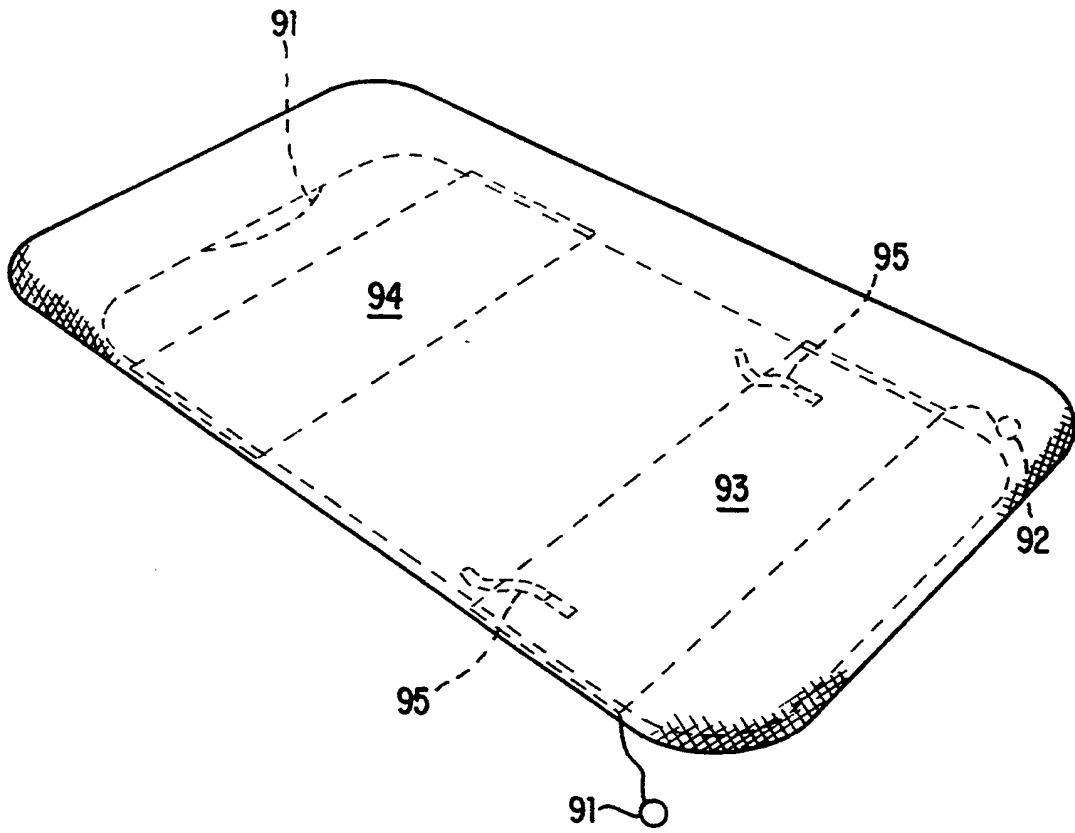

FIG. 10

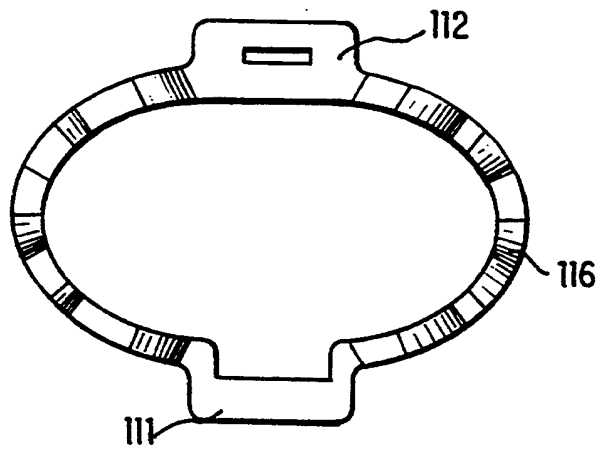

FIG. 13

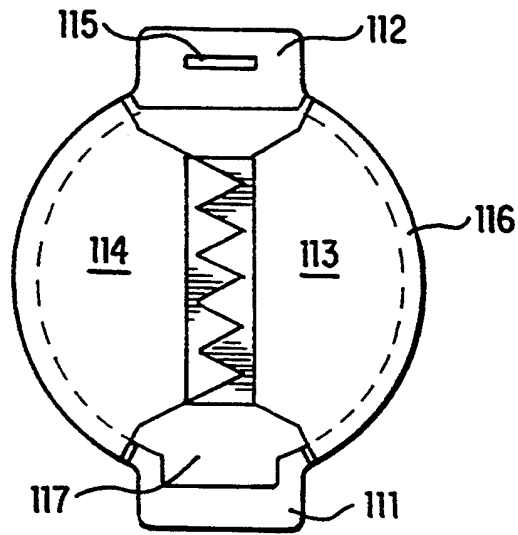

FIG. 11

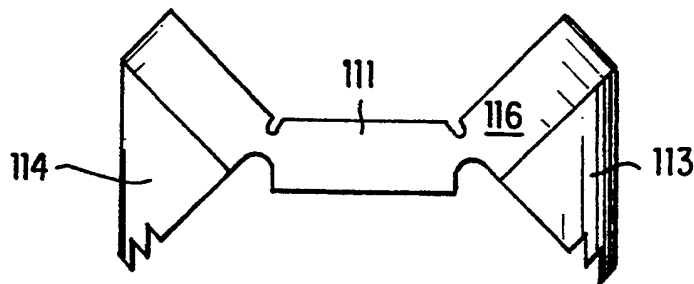

FIG. 14

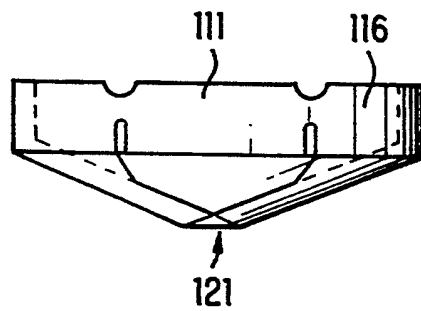

FIG. 12

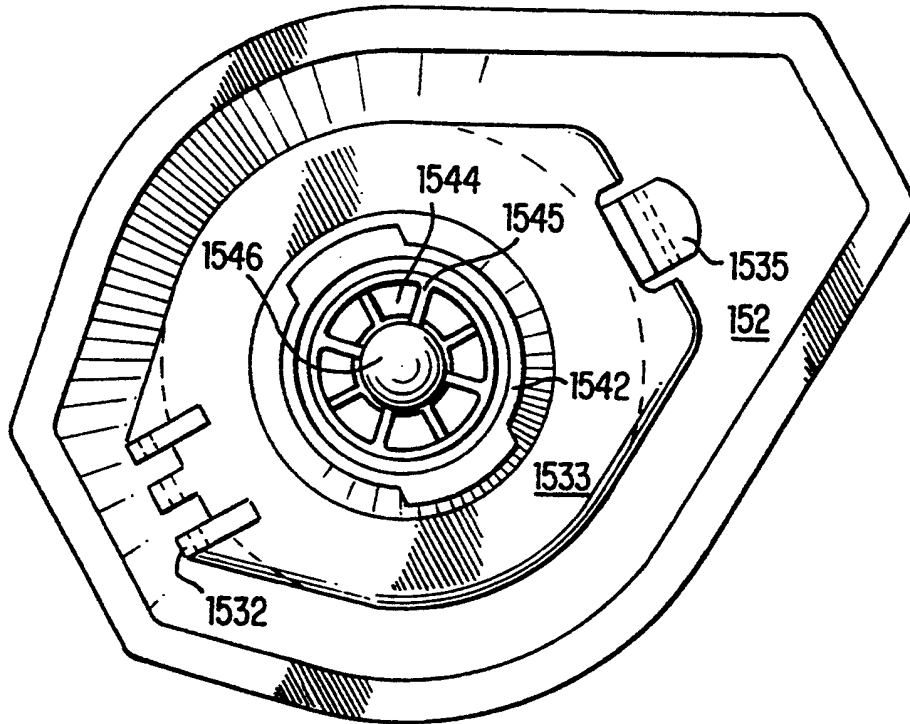

FIG. 17

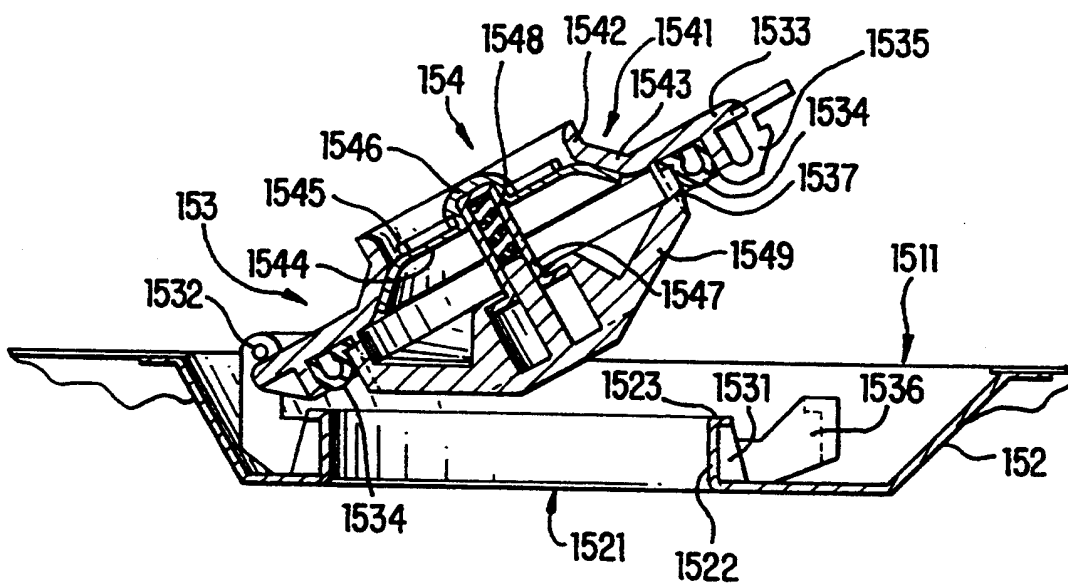

FIG. 15

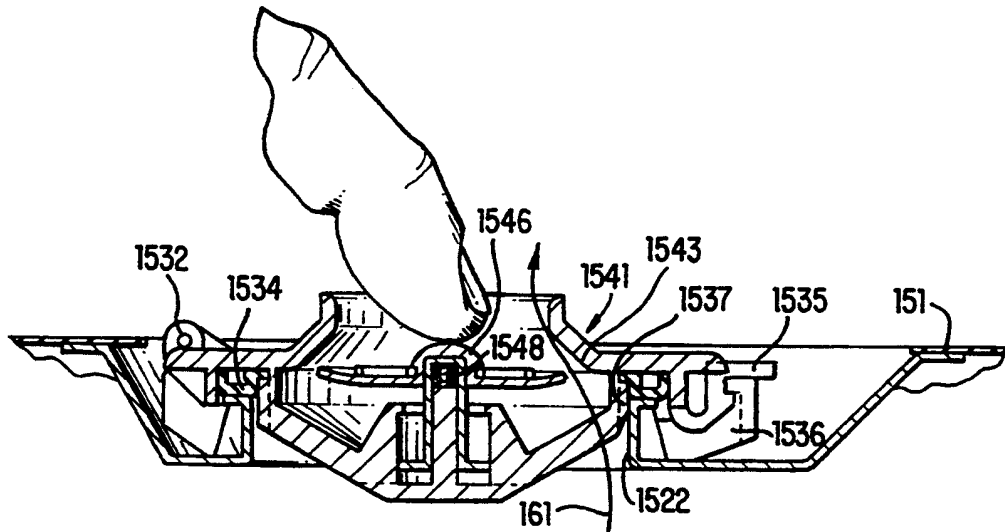

FIG. 16

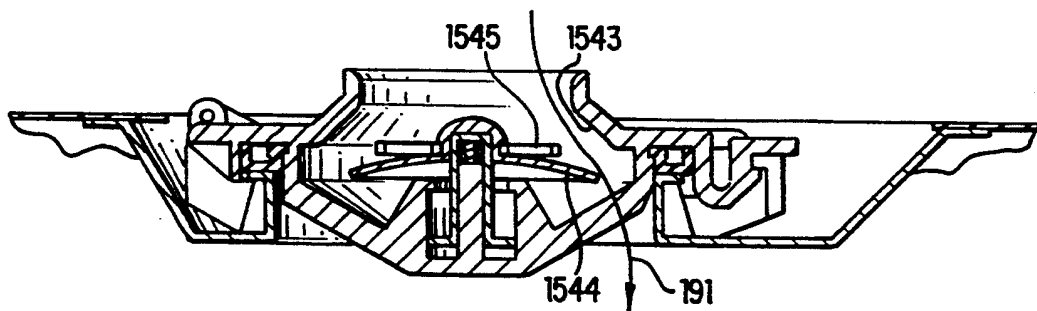

FIG. 19

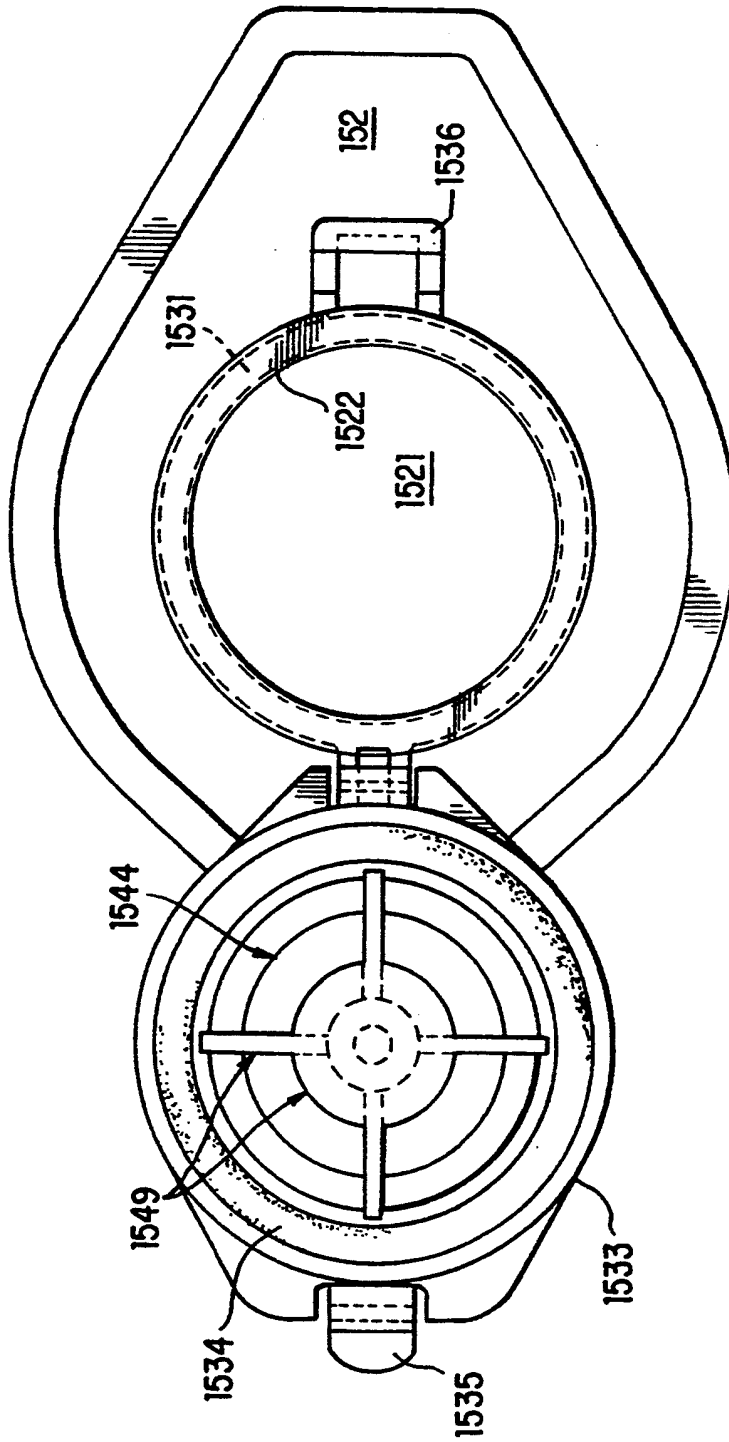

FIG. 18

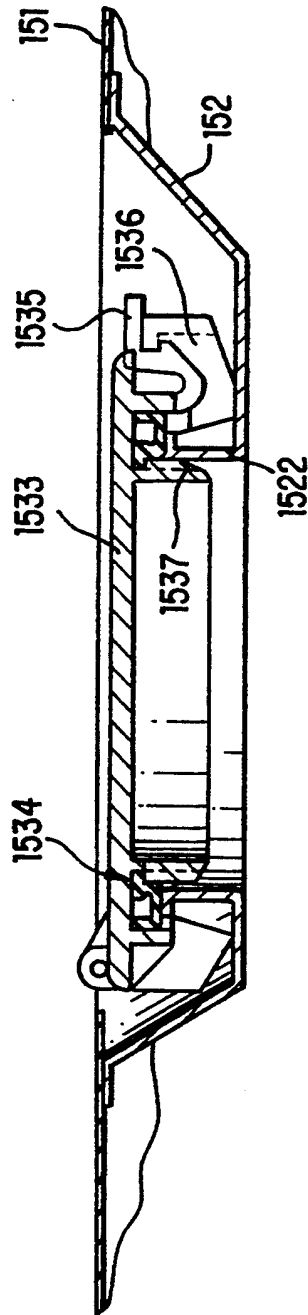

FIG. 20

PNEUMATIC SUPPORT SYSTEM

The present application is a continuation-in-part of U.S. application Ser. No. 07/764,337, filed Sep. 23, 1991, which is a continuation-in-part of U.S. application Ser. No. 07/557,943, filed Jul. 25, 1990, now abandoned which in turn is a continuation-in-part of U.S. application Ser. No. 07/384,786, filed Jul. 25, 1989 and now issued as U.S. Pat. No. 4,977,633. These related applications are hereby incorporated herein by reference.

TECHNICAL FIELD

The present invention relates to inflatable support systems, which may include air mattresses, and inflation and control thereof.

SUMMARY OF THE INVENTION

The invention provides in one embodiment a portable, inflatable support system, and a portable inflator for use with such a system. According to one embodiment of the invention, the inflatable support system may include an inflatable mattress having a pressure valve and a battery powered inflator for removable engagement therewith, which on engagement is automatically powered for a predetermined time or until a predetermined pressure is achieved. The mattress may be readily expanded for use and collapsed for storage.

In accordance with another embodiment of the invention, there is provided a multipurpose pressure control, for manual adjustment to provide an inflatable support system of desired firmness, and to modify the posture of the reclining user. In accordance with another embodiment of the invention, a dual valve assembly including a cover assembly covers a throat, and the cover assembly is itself provided with a one-way valve.

In accordance with another embodiment of the invention, there is provided an in-place bedding system, including a mattress, mattress cover, and top and bottom sheets, which retain their functional arrangement when the bed is collapsed for storage and prepared for use, thereby eliminating the necessity for re-making the bed with each use.

BRIEF DESCRIPTION OF THE DRAWINGS

The foregoing features of the invention will be more readily understood by reference to the following detailed description taken with the accompanying drawings, in which:

FIG. 1 illustrates an inflatable mattress in accordance with a preferred embodiment of the invention.

FIG. 2 illustrates a portable battery powered inflation device for use with the embodiment of FIG. 1.

FIGS. 3 and 4 illustrate the dual valve assembly depicted in FIG. 2.

FIGS. 5 through 7 illustrate a multipurpose pressure control in accordance with another preferred embodiment of the invention.

FIGS. 8-10 illustrate an in-place bedding system in accordance with another preferred embodiment of the invention, and a mattress cover used in connection herewith.

FIGS. 11-14 provide detail of the sheet retainer rings shown in FIGS. 9 and 10.

FIGS. 15-19 illustrate an alternative embodiment of the dual valve assembly depicted in FIG. 2.

FIG. 20 illustrates a manually operable air release valve for a body support using a structure similar to that shown in FIGS. 15-19.

DETAILED DESCRIPTION OF SPECIFIC EMBODIMENTS

A first embodiment of the invention illustrated in FIG. 1 provides an inflatable support system including an inflatable mattress 10 having a dual valve assembly 12 affording support and comfort for the user. The mattress 10 additionally is conveniently and readily inflated and assembled or deflated and stored. Although in the examples that follow, it is assumed that inflation of the mattress is achieved using air, in fact any suitable fluid may be used for inflation, such as water or nitrogen, and if desired appropriate means may be supplied for collection or drainage of fluid expelled from the mattress in the course of adjustment or deflation for storage purposes. Furthermore, although the embodiments described below are with reference to an inflatable mattress, in fact they are applicable to any inflatable body support, including an inflatable chair or pillow, or any other low pressure inflatable body.

In FIG. 2 is illustrated detail of the dual valve assembly 12 engaged with a portable battery powered inflation device 20 in accordance with a preferred embodiment of the invention. The inflation device includes a dc motor 25, powered by rechargeable batteries 22a and 22b, and an impeller 21 driven by the motor 25, all mounted in a housing 26 having a mouth region 28 that is removably engagable with the inflation input (discussed below in connection with FIG. 3 as item 322) of the dual valve 12. The method of engagement may be by screw threads 27 or by other suitable means known in the art, such as a bayonet mount permitting quick connection and disconnect. Also disposed in the housing 26 are control circuitry for controlling the motor, sensing arrangement 24 for sensing when the mouth 26 of the housing is engaged with the inflation input of the dual valve 12, and dc battery recharging input 29. The housing 26 may also be provided with a suitable arrangement for covering the mouth region 28 and the air inlet 281. Although numerous such arrangements are possible, one arrangement may include a snap-on C-shaped clip that is pivotally mounted along a vertical axis of the inflation device 20 of FIG. 2 to permit the clip to swing off the mouth 28 and the air inlet 281. The control circuitry 23 is connected to the batteries 22a and 22b over lines 231 and 233 respectively, to the motor 25 over line 232, to the sensing arrangement 24 over line 234, and to the recharging input 29 over line 235. The sensing arrangement may be a simple contact switch, mounted in the mouth 28, that is closed by motion of the threads of the inflation input when it is engaged with the mouth 28. Alternatively, for example, the sensing arrangement may be a Hall effect device mounted in the mouth 28 that is triggered by proximity to a magnet mounted in the inflation input.

The control circuitry 23 is configured, by means well known in the art, to deliver power to the motor 25 from the time that the sensing arrangement 24 has detected engagement of the mouth 26 with the inflation input of the dual valve 12. In this manner, pumping of air into the mattress begins only after, and as soon as, the inflation device 20 has been properly engaged. Similarly, the control circuitry is configured to cease delivering power when the inflation device 20 is no longer engaged, so that it may be easily turned on and off without

the need for an external switch. When the inflation device 20 is engaged with the mattress, the control circuitry 23 continues to deliver power to the motor 25 until a predetermined condition has been achieved. In one version of this embodiment, the battery-motor-impeller combination is designed to provide a maximum air pressure that does not exceed the maximum desired pressure in the mattress. In such a case, for a mattress of a given size, once a predetermined time has elapsed for delivery of air to the mattress by the inflation device 20, the maximum desired pressure will have been reached.

Accordingly, the control circuitry is designed to cease delivering power to the motor 25 when a predetermined time has elapsed after the sensing arrangement 24 has sensed engagement of the mouth 26 with the inflation input of the dual valve 12. With a typical air mattress and a typical design for an inflation device, for example, maximum pressure may be achieved in about one minute, so the control circuitry provides a timed shutoff after one minute. It is apparent that the timed shut-off feature provides desirable conservation of battery power, and conservation may be enhanced if shut-off occurs at full inflation—i.e. when the inflation device has first achieved the maximum pressure in the air mattress of which it is capable, assuming that this maximum does not exceed the maximum desired pressure in the mattress. Indeed, such an approach permits use of a relatively small and lightweight inflation device. If the user is prepared to provide manually (i.e., by blowing) the final bolus of air to achieve the desired pressure, the inflation device may be smaller still. Such a design spares the user of the time-consuming and headache-producing task of filling the mattress manually, while permitting a compact and lightweight construction for the inflation device 20.

Alternatively, the control may take advantage of the fact that air flow from the inflation device 20 to the inflation input of the dual valve 12 has substantially ceased when the maximum desired pressure has been reached, assuming that the battery-motor-impeller combination is designed to provide a maximum air pressure that does not exceed the maximum pressure in the mattress. In this alternative configuration, the inflation device 20 may be further provided with a flow sensor, and the control circuitry 23 may be configured to cease delivering power after substantial air flow has ceased. The flow sensor in such a configuration may be implemented by a vane (shown in phantom) 201 mounted on a pivot 202 and having an arm 203 that keeps a normally open microswitch (shown in phantom) 204 closed only as long as air flow is substantial, and the microswitch is connected to the control circuitry 23 over line 236. The control circuitry 23 is then configured to provide initial power to the motor 25 independently of the position of microswitch 204 until a period of time has elapsed to permit the establishment of initial flow to cause closure of the microswitch.

In a related alternative embodiment of the device 20 shown in FIG. 2, there may be provided a pressure transducer that is connected to the control circuitry 23, which may be configured to cease providing power to the motor 25 after a predetermined pressure has been reached.

FIGS. 3 and 4 show a cross section and a top view respectively of the dual valve assembly depicted in FIG. 2. This valve assembly is similar to the valve assembly shown in FIGS. 11-13 of my prior U.S. application Ser. No. 07/557,943, filed Jul. 25, 1990. Inflation is

provided to the mattress 10 by means of the inflation input 322 having exterior threads 321, which are capable of being engaged with mating threads of the inflation device 20 described above. As previously discussed, the means of achieving the engagement with the inflation device is a matter of design choice, and alternative embodiments, such as the use of a bayonet mount, are within the scope of the present invention. Air pressure at the inflation input 322 causes the downward displacement of diaphragm 34 away from its valve seat 36, thereby permitting air flow through the first cylinder 32 via the triangular passageways 37. When air has been placed within the mattress 10 under modest pressure, however, and air pressure is removed from inflation input 322, the pressure of air in the mattress 10 urges the diaphragm 34 against valve seat 36 and produces a positive seal against the exit of air from the mattress. An optional spring 311 may be used to assure a positive seal even in the absence of substantial pressure within the mattress 10. This seal can be momentarily overridden by pressing downwardly on stem 31, which causes the downward motion of the diaphragm away from the valve seat 36, and permitting the exit of controlled amounts of air through the passageways 37. Thus the valve design permits the reduction of air pressure in the mattress from any excess that may have occurred on inflation to a desired optimum pressure, simply by pressing on the stem 31. The quality of air released by the valve may be controlled by the distance the valve stem 31 is initially depressed (letting air pressure within the mattress 10 force the valve to return to a closed position); for example, a one-eighth inch depression provides a subtle decrease in pressure and a one-half inch depression a more substantial pressure drop. It should be pointed out that the valve described herein typically functions over a pressure range from approximately $\frac{1}{4}$ to 1 lb of pressure per square inch (2 to 7 kpa), a region in which it is typically difficult to achieve good control simultaneously with an effective seal. The diameter of first cylinder 32 is large enough (typically about 1.25 inches (3 cm) or more) to permit the rapid inflation of the mattress with a substantial flow of air at relatively low pressure.

The valve assembly just described, including first cylinder 32, diaphragm 34, and stem 31, is mounted concentrically within a second cylinder 33, and is itself hingedly mounted so as to cover the opening of the second cylinder 33. The opening is defined by rim 38, and against which is mated cover seal 39. The hinge pivot 35 permits the valve assembly to uncover the opening 33, which is large enough to permit the rapid and easy deflation of the mattress by expelling air through the opening of cylinder 33, which is typically about 2 inches (5 cm) or more. The opening of the cylinder 33 is sealed when the mattress is in use by latch 36, which is disposed on the opposite side of the assembly from pivot 35, and causes rim 38 to be hugged by cover seal 39. Although the embodiment illustrated herein shows the use of a hinge 35 and a latch 36, it may be seen that the valve assembly described previously may be secured to cover the second cylinder 33 by other means known in the art, including a bayonet mount that is secured after engagement by rotation. Alternatively there may be employed a combination bayonet-hinge assembly, configured so that after the bayonet is disengaged by counter-rotation, a pivot (similar to item 35, but carried on a short arcuate track mounted to the second cylinder so as to permit rotation

of the bayonet) permits the valve assembly to uncover the opening defined by rim 38 in a manner similar to that described above.

In order to permit unrestricted air flow into (or out of) the air mattress when it is in a collapsed or near-collapsed condition, the housing for the second cylinder is provided with a plurality of stand-offs 331 that prevent the inner surface of mattress 10 from fully occluding the opening of the second cylinder 33 to the mattress interior. Similarly, a series of openings 323 in the inner extremity of the first cylinder 32 prevent the inner surface of mattress 10 from fully occluding the opening of the first cylinder to the mattress interior.

FIGS. 5 through 7 illustrate another preferred embodiment of the invention, in this case providing a multipurpose pressure control. FIG. 5 is a side view of the embodiment with the mattress 10 moved out of the way. FIG. 6 is a vertical section taken through plane VI—VI of FIG. 5, and FIG. 7 is a top view of the embodiment of FIG. 5. In this embodiment, in a manner similar to that of the embodiment of FIG. 1 of U.S. application Ser. No. 07/557,943, filed Jul. 25, 1990, a housing 57 contains a line-powered motor-driven fan to pump air into the mattress 10 and also serves as a mandrel upon which the deflated mattress may be wound; a large diameter valve at the foot of the mattress (not shown in these figures) may provide rapid deflation of the mattress. Power is supplied via plug 53, line cord 54 and a switch contained in assembly 51. Region 55 of the housing 57 contains a motor and fan to provide air pressure to inflate the mattress 10. The motor and fan may be designed, as described above, in connection with FIG. 2, to provide a maximum air pressure that does not exceed the maximum desired pressure in the mattress and may employ control circuitry of the type described above to turn off the motor once a desired pressure has been reached. Region 56 of the housing contains a one-way valve, similar to the valve assembly associated with the first cylinder 32 described in relation to FIGS. 3 and 4 above. Recessed in the top of switch assembly 51 is switch button 511 for turning on the fan motor. Normally switch assembly 51 is unmounted and moves freely as part of line cord 54. Thus, when the unit is plugged in and the switch in assembly 51 is turned on, the mattress is inflated and unwinds from the housing 57. After the mattress is inflated, the switch assembly 51 may then be placed in removable engagement with receptacle 58 on housing 57.

Receptacle 58 is formed on a flexible membrane forming at this point the exterior of housing 57 and disposed over stem 61 (corresponding to stem 31 of FIG. 3) associated with diaphragm 62 (corresponding to diaphragm 34 of FIG. 3). The walls of cylinder 63 (corresponding to cylinder 32 of FIG. 3) are attached on the outside to air mattress 10, and define an opening 64 through which air from the fan is pumped when the fan motor is energized. The housing 57 is removably engaged with the walls of cylinder 63, permitting replacement of the air mattress 10 or motor fan unit if one of them fails.

It can be seen that pressing button 511 causes the fan motor to run and increases pressure in the mattress. Similarly, moving the entire assembly 51 in a downward direction causes force to be transmitted, through rod 64 and walls 52 of the assembly 51, and the flexible membrane of receptacle 58, to the stem 61 of the valve, causing diaphragm 62 to let air out of the mattress. This embodiment therefore provides an easily operable mul-

tipurpose pressure control that in a first position causes air pressure in the mattress to increase and in a second position causes air pressure in the mattress to decrease. Because the housing 57 and related fittings are disposed at an end of the mattress 10, the control may be suitably located and reached at the head of the mattress, and is therefore accessible to a user while on the mattress. The multipurpose pressure control consequently permits the user to adjust the mattress air pressure for the user's personal comfort while on the mattress and without interruption of body contact with the mattress. As pressure adjustments may occur during the night, in darkness, with the user in a semi-awake, semi-conscious state, the control may be operated without vision, excessive manipulation, or major changes in posture. It should be noted that this embodiment permits both gross and subtle adjustments in mattress air pressure, thereby providing a sleep surface which accommodates a wide variety of comfort requirements. Additionally, in connection with embodiments, such as described in connection with FIG. 1 of my application Ser. No. 07/557,943, filed Jul. 25, 1990, wherein the motor-driven fan assembly lies at the head of the mattress, motion of assembly 51 can be used to partially deflate the mattress to permit the user to recline, while using the motor-driven fan assembly to support a pillow; such a position is comfortable for reading and the like. At low inflations, the mattress may still provide complete suspension of the body, while also providing a difference in the range of 6–8 inches (15–20 cm) in elevation between feet and torso.

Although the embodiment described in connection with FIGS. 5–7 uses a mixed mechanical and electrical system, it would be possible to use a control that is entirely actuated electronically, for example, employing a solenoid to move the valve stem 61 to open the diaphragm 62, and a three position switch that in a first position energizes the fan motor, in a second position energizes the solenoid, and in a third position energizes neither. Additionally, it is within the scope of the invention to provide a control that causes a predetermined increment of inflation or deflation in accordance with a user's selection. The increment may be determined, for example, by a timing device or a pressure measurement device.

The pneumatic support system of the present invention offers space-saving and time-saving advantages in comparison to prior art portable or temporary bed arrangements. In its fully expanded "in-use" state, the pneumatic support system herein occupies the same amount of space as a conventional mattress. Yet in a collapsed "storage" state, the support system returns almost 90% of that space to the user. In order for the user to fully realize the benefits of this advantage, the support system must allow the transition to and from storage to occur with maximum efficiency and ease. With the support system in accordance with the present invention, set-up and take-down require as little as 15 to 30 seconds.

In order to take full advantage of the utility offered by the support system in accordance with the present invention, a special bedding system is advantageous. When conventional covers and bedsheets are used with the present invention, they may become misaligned as it is being moved to and from storage, requiring that the support system be made over with bedding with each use. Since the movement in and out of storage may often occur on a daily basis, considerable time and effort

are lost through the requirement to re-make. The in-place bedding system of the present invention eliminates the problem of bedding misalignment.

FIGS. 8-14 pertain to the in-place bedding system of the present invention. The in-place bedding system includes a special mattress cover that permits use of a conventional fitted bottom bedsheet and a conventional top bedsheet, which will retain their functional relationships not only while in use, but also during and after the collapsing of support system for storage thereby eliminating the necessity for re-making the bed with each use.

The exterior of the mattress cover 81, shown in FIG. 8 in a top view, much like a fitted bedsheet, wraps around all four sides of the mattress. The cover assembly includes a padding material 82 sewn to the underside of the cover's top surface. This material may be foam rubber, synthetic fiber, a combination thereof, or other suitable material.

In FIG. 9 is shown a bottom view of the cover 81, which includes two cross-connectors 93 and 94 sewn to the bottom edges of the cover at positions 941 and 942 for connector 94 and 931 and 932 for connector 93. The cross-connectors 93 and 94 span the mattress bottom from side to side, securing the position of the mattress cover for multiple re-use (repeated cycles of inflation and deflation). On both sides of the cover, near the foot end, are sheet retainer rings 91 and 92, attached to the cover by elastic straps. These retainer rings, discussed in further detail in connection with FIGS. 11-14, have the purpose of securing the position of a conventional top sheet for multiple re-use while, at the same time, allowing the flexibility and movement necessary for comfortable sleeping. Controller strap 91 runs around the inner periphery 99 of the cover 81 and is pulled and tightened in a manner known in the art to assure that the cover 81 tightly hugs the mattress. A pair of roll straps 95 are attached at one end to connector 93. When the mattress and mattress cover are rolled up as an assembled unit (possibly using the housing of a motor-driven fan as a mandrel in the fashion described in connection with FIG. 5, and possibly including top and bottom bedsheets as described below), the other end of each of roll strap 95 may be passed through the open region 117 near the ear 111 (see FIG. 11) of a corresponding retaining ring 91 or 92 and thereafter attached to itself via Velcro or similar hook-and-loop type fastening material. In this way, the rolled up assembly may be maintained in a compact condition and easily readied for reuse in accordance with procedures described above. FIG. 10 is a perspective view from above of the general features described in connection with FIG. 9.

Initial set-up of the support system in accordance with FIGS. 8-10 includes the following:

1. Insertion of the deflated mattress into the mattress cover 81.
2. Inflation of the mattress while checking for proper alignment of mattress and cover.
3. Installation of the bottom bedsheet (a standard fitted sheet).
4. Installation of the top bedsheet by laying it on the inflated bed and then drawing the two corners of the sheet through the bedsheet at its foot-end retainer rings 91 and 92, so that the bedsheet has a reasonably snug fit, conforming to the foot-end of the mattress.

Once these steps are taken, mattress, mattress cover, bottom bedsheet, and top bedsheet become a semi-permanent assembly, fixed in position for multiple re-use.

Detail of the retainer rings 91 and 92 is provided in FIGS. 11-14. The retainer ring is a spring fastener, and may be fabricated from a variety of resilient materials including various plastics, such as polyethylene. FIGS. 11 and 12 provide side and top views of the retainer ring, which include slot 115 for attachment to the strap and ears 111 and 112. When ears 111 and 112 are squeezed toward one another, the peripheral wall 116 is deformed, as shown in FIG. 13 (also presenting a top view) and jaws 114 and 113 are caused to open, as shown in FIG. 14 (presenting a side view). FIG. 12 shows the region 121 wherein the teeth of the jaws 113 and 114 are engaged with one another when the ears are not squeezed together. In this embodiment, the peripheral wall, the jaws, and the ears are all formed as part of an integral structure.

Squeezing ears 111 and 112 toward one another allows insertion of the corner of the bedsheet through the jaws 114 and 113 of the ring. The top bedsheet corner may then be easily drawn through the ring to achieve proper fitting of the bedsheet to the bed. Once the sheet is in position (and the squeezing of the ears is released), the spring action of the ring applies pressure to the jaws and in turn on the inserted bedsheet portion, locking the inserted portion of the bedsheet in place, and securing the position of the sheet on the bed. For bedsheet removal, one merely squeezes together the ears 111 and 112 of the ring, and the bedsheet is automatically released.

The retainer ring provides convenience and ease in the use of conventional bedsheets for initially setting-up the bed, for changing bedsheets, and for providing a fixed bedding assembly that eliminates the need for re-making the bed with each use.

Although the foregoing embodiment has been described as a mattress cover, the essential features of the foregoing cover may be directly incorporated into the surface of the mattress. The padding material 82 may then be attached to the top surface of the mattress, provided with a suitable covering layer.

In FIG. 15 is shown a cross-section of a dual valve assembly that is an alternative to the embodiment depicted in FIG. 2. FIG. 16 shows the same assembly in cross-section with the cover assembly 153 in a closed position. FIG. 17 is a top view of the embodiment of FIGS. 15 and 16 with the cover assembly also in a closed position. In FIG. 18 is shown a top view of this same embodiment with the cover assembly in an open position. FIG. 19 is a cross-section of the same embodiment showing the air path through it during inflation.

In FIG. 15 the wall 151 of an inflatable body is shown to be provided with a port 1511 through which air is transferred between the exterior and the interior of the inflatable body. A flange 152 is mounted to the wall of the inflatable body in a location proximate to the port 1511. The flange 152 has a throat 1521 through which all air passes in the course of being transferred between the interior and exterior of the inflatable body. The throat 1521 is defined by a circular rim 1522 of the flange. A cover assembly 153 is used to removably cover the throat 1521. A ring-shaped base 1531 is disposed around the exterior of the rim 1522. Preferably the base is removable from the rim and is retained by top portion 1523 of the rim. Alternatively, the rim 1522 and the base 1531 may be integrally formed. Cap 1533 is

attached to the base 1531 by means of hinge assembly 1532. The cap is latched into a closed position by a latching arrangement including latch projection 1535 on the cap and latch receptacle 1536 on the base. When the cap 1533 is closed, gasket 1534 is urged against the top 1523 of the rim 1522. In the closed position of the cap, the gasket 1534 is submitted to compression, and the gasket itself is formed of flexible material presenting, to the top of the rim, in profile a convex arcuate portion. The convex shape of the gasket 1534 may be achieved as shown here by use of a flexible sheet of material retained in an inverted U configuration or by use of a suitable O-shaped gasket.

It is convenient to make the flange 152 of flexible material. Under such circumstances, the rim 1522 may be subject to deformation, an eventuality that may interfere with an effective seal with the cover assembly 153. The deformation may be reduced by integrally forming the rim 1522 with the base 1531. Alternatively, it is convenient to provide a lip 1537, disposed peripherally around the cap, in such a way that, when the cap is in a closed position, the lip 1537 mates with the interior of the rim 1522. In this way, the flexible rim 1522 is squeezed between the lip 1537 and the base 1531, thereby reducing the risk of deformation of the rim.

Disposed in the cover assembly 153 is valve assembly 154. The valve assembly includes a diaphragm 1544 and valve stem 1547 that move axially in the assembly 154. The valve stem 1547 and diaphragm 1544 are supported by valve stem support 1549, which is attached to the cap 1533. The cap also includes the structure defining the inflation input 1542 and valve seat 1543 of the valve assembly 154.

A circular coupling 1541 includes an open end that constitutes the inflation input 1542. It also has a flared end that provides the valve seat 1543 in the form of a circular lip. Mounted adjacent to the diaphragm is diaphragm stiffener 1545, which serves to stiffen the diaphragm except in the outer annular region that is in contact with valve seat 1543.

It can be seen that the diaphragm can be accessed by an individual directly from the inflation input 1542 and can be pushed axially into an open position. Such a process is illustrated in FIG. 16. To facilitate this motion, the diaphragm is provided with push button 1546.

The diaphragm is urged into a closed position by spring 1548, shown here disposed within the valve stem 1547 and pushing against a portion of valve stem support 1549. As can be seen in FIG. 18, the valve stem support 1549 includes here four supporting members spaced around the assembly, but permits the ready passage of air through the throat.

As shown in FIG. 17, the inflation input 1542 may be provided with a bayonette mount or other means for affixing an inflation device.

FIGS. 16 and 19 show relative air flow during deflation (FIG. 16) and inflation (FIG. 19) shown by arrows 161 and 191 respectively. It can also be seen that during inflation the stiffener 1545 is configured in such a way as to permit the diaphragm 1544 to bend towards the interior of the inflatable body and away from the valve seat 1543. This arrangement facilitates the massive flow of air at low pressure into the inflatable body, while still providing resistance to deformation of the diaphragm when it is in a closed position such as shown in FIG. 15.

What is claimed is:

1. An inflatable system, comprising: an inflatable body having an interior, an exterior, a port for transfer

of air between the interior and exterior and a wall separating the interior and exterior;

a flange attached to the wall proximate to the port and having a throat, defined by a deformable rim around the perimeter thereof, the rim having interior and exterior sides and a top, the throat disposed within the port, and the flange configured in the port to required all air being transferred between the interior and exterior of the body to pass through the throat; and

an assembly for removably covering the throat, the assembly including: (i) a substantially rigid ring-shaped base disposed around the exterior of the rim and configured to limit the radially outward expansion of the rim, (ii) a cap removably attached to the base, and (iii) shape means for restricting radially inward movement of the rim at least when the cap is in a closed position, so that when the cap is in an open position, the throat is uncovered, and when the cap is in a closed position, the throat is covered by the cap.

2. A system according to claim 1, wherein the shape means is a peripheral lip attached to the cap and is so configured that when the cap is in a closed position, the lip is seated in the interior of the rim.

3. A system according to claim 1, wherein the ring-shaped base is removably disposed around the exterior of the rim and retained by the top of the rim.

4. A system according to claim 1, wherein the cap is hingedly attached to the base and the assembly includes latch means for releasably latching the cap in a closed position upon a push on the cap.

5. A system according to claim 4, wherein the latch means includes a projection on the cap and a mating receptacle for the projection on the ring.

6. A system according to claim 1, further comprising: a valve, disposed in the cap, functioning independently of the cap when the cap is in a closed position.

7. A system according to claim 2, wherein the assembly further includes a gasket disposed concentrically outside the lip, the gasket compressively meeting with the top of the rim when the cap is in a closed position.

8. A system according to claim 7, wherein the gasket is formed of flexible material presenting, to the top of the rim, in profile a convex arcuate portion thereof.

9. An inflatable support system, comprising: an inflatable body having an interior, an exterior, and inflation input for transfer of air between the interior and exterior; and

a one-way valve, disposed between the interior and the inflation input, for controlling the transfer of air, providing a substantially hermetic seal under low pressure conditions, such valve including:

a passageway having a general circular cross section and a first end in communication with the interior and a second end in communication with the inflation input;

a circular lip, disposed peripherally in the passageway and protruding radially inward, having a first surface generally facing the interior, defining a valve seat;

a flexible circular diaphragm, having an interior surface generally facing the interior and an outer surface facing away from the interior mounted for axial movement in the passageway away from and against the valve seat in respectively open and closed positions of the valve, so that an outer annu-

11

lar region of the outer surface of the diaphragm engages against the valve seat in the closed position; and

- a generally circular coupling defining the passageway, the coupling having an open end defining the inflation input and a flared end, contiguous therewith, providing the circular lip, so that the (i) the coupling at the open end has a smaller internal diameter than at the flared end and (ii) the diaphragm can be pushed axially to open the valve by reaching into the open end of the coupling.
- 10. A support system according to claim 9, wherein the valve further includes:
 - a valve stem centrally mounted on the inner surface of the diaphragm; and
 - a valve stem support mounted to the coupling distally from the open end thereof, to permit axial movement of the valve stem and diaphragm.
- 11. A support system according to claim 10, wherein the valve further includes:
 - a valve spring disposed in relation to the valve stem support and the diaphragm in such a manner as to urge the diaphragm into a closed position; and
 - a circular diaphragm stiffener disposed adjacent to the diaphragm to reduce flexing of the diaphragm except in its outer annular region.
- 12. An inflatable body comprising:
 - an inflatable bladder having an interior and an inflation input;
 - a one-way valve disposed between the interior and the inflation input providing a substantially hermetic seal under low pressure conditions, such valve including:
 - a passageway having a generally circular cross section and a first end in communication with the interior and a second end in communication with the inflation input;
 - a circular lip, disposed peripherally in the passageway and protruding radially inward, having a first surface generally facing the interior, defining a valve seat;
 - a flexible circular diaphragm, having an inner surface generally facing the interior and an outer surface facing away from the interior, mounted for axial movement in the passageway away from and against the valve seat in respectively open and closed positions of the valve, so that (i) the act of inflation of the bladder under low pressure is sufficient to cause axial motion of the valve into the open position to permit the large influx of air and (ii) following inflation of the bladder, air pressure created in the interior the bladder by inflation thereof causes an outer annular region of the outer surface of the diaphragm to be urged into engagement against the valve seat to provide a complete hermetic seal when the valve is in the closed position; and
 - stiffening means for reducing flexing of the diaphragm except in its outer annular region.

12

13. An inflatable bed according to claim 12, wherein the first surface is disposed at an oblique angle with respect to the radius of the passageway.

14. An inflatable bed according to claim 12, further comprising a stem attached to the diaphragm's outer surface to permit ready opening of the valve.

15. An inflatable bed according to claim 13, further comprising a stem attached to the diaphragm's outer surface to permit ready opening of the valve.

16. An inflatable bed according to claim 12, further comprising:

a conduit in which the passageway and the associated one-way valve are concentrically and removably disposed to form a cap, the conduit having a first end in communication with the interior and a second end that is normally covered by the cap; and latching means for releasably latching the cap over the second end of the conduit, so that when the latching means is released, the passageway and associated valve may be removed from covering the second end of the conduit, whereby the bladder may be rapidly and easily deflated.

17. An inflatable bed according to claim 14, further comprising:

a conduit in which the passageway and the associated one-way valve are concentrically and removably disposed to form a cap, the conduit having a first end in communication with the interior and a second end that is normally covered by the cap; and latching means for releasably latching the cap over the second end of the conduit, so that when the latching means is released, the passageway and associated valve may be removed from covering the second end of the conduit, whereby the bladder may be rapidly and easily deflated.

18. An inflatable bed according to claim 15, further comprising:

a conduit in which the passageway and the associated one-way valve are concentrically and removably disposed to form a cap, the conduit having a first end in communication with the interior and a second end that is normally covered by the cap; and latching means for releasably latching the cap over the second end of the conduit, so that when the latching means is released, the passageway and associated valve may be removed from covering the second end of the conduit, whereby the bladder may be rapidly and easily deflated.

19. A system according to claim 11, further comprising a push button centrally disposed on the outer surface of the diaphragm for pushing the diaphragm into the open position when desired for depressurization of the inflatable body.

20. A system according to claim 12; further comprising a push button centrally disposed on the outer surface of the diaphragm for pushing the diaphragm into the open position when desired for depressurization of the inflatable body.

* * * * *